

Wow & Flutter Meter HM 8026

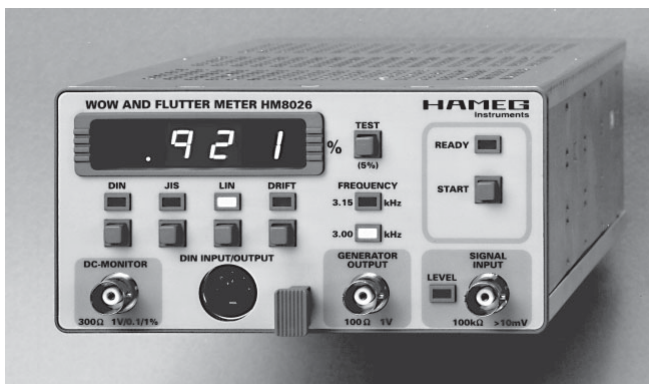

General information regarding the CE marking

HAMEG instruments fulfill the regulations of the EMC directive. The conformity test made by HAMEG is based on the actual generic- and product standards. In cases where different limit values are applicable, HAMEG applies the severer standard. For emission the limits for residential, commercial and light industry are applied. Regarding the immunity (susceptibility) the limits for industrial environment have been used.

The measuring- and data lines of the instrument have much influence on emission and immunity and therefore on meeting the acceptance limits. For different applications the lines and/or cables used may be different. For measurement operation the following hints and conditions regarding emission and immunity should be observed:

1. Data cables

For the connection between instruments resp. their interfaces and external devices, (computer, printer etc.) sufficiently screened cables must be used. Without a special instruction in the manual for a reduced cable length, the maximum cable length of a dataline must be less than 3 meters long. If an interface has several connectors only one connector must have a connection to a cable.

Basically interconnections must have a double screening. For IEEE-bus purposes the double screened cables HZ72S and HZ72L from HAMEG are suitable.

2. Signal cables

Basically test leads for signal interconnection between test point and instrument should be as short as possible. Without instruction in the manual for a shorter length, signal lines must be less than 3 meters long.

Signal lines must be screened (coaxial cable - RG58/U). A proper ground connection is required. In combination with signal generators double screened cables (RG223/U, RG214/U) must be used.

3. Influence on measuring instruments.

Under the presence of strong high frequency electric or magnetic fields, even with careful setup of the measuring equipment an influence of such signals is unavoidable.

This will not cause damage or put the instrument out of operation. Small deviations of the measuring value (reading) exceeding the instruments specifications may result from such conditions in individual cases.

KONFORMITÄTSERKLÄRUNG
DECLARATION OF CONFORMITY
DECLARATION DE CONFORMITE



HAMEG[®]
Instruments

Name und Adresse des Herstellers
Manufacturer's name and address
Nom et adresse du fabricant

HAMEG GmbH
Kelsterbacherstraße 15-19
D - 60528 Frankfurt

HAMEG S.a.r.l.
5, av de la République
F - 94800 Villejuif

Die HAMEG GmbH / HAMEG S.a.r.l bescheinigt die Konformität für das Produkt
The HAMEG GmbH / HAMEG S.a.r.l herewith declares conformity of the product
HAMEG GmbH / HAMEG S.a.r.l déclare la conformite du produit

L-C Meter / LC-METRE / Medidor LC

Bezeichnung / Product name / Designation: **HM8026**

Typ / Type / Type: **HM8001-2**

mit / with / avec:

Optionen / Options / Options:

mit den folgenden Bestimmungen / with applicable regulations / avec les directives suivantes

EMV Richtlinie 89/336/EWG ergänzt durch 91/263/EWG, 92/31/EWG
EMC Directive 89/336/EEC amended by 91/263/EWG, 92/31/EEC
Directive EMC 89/336/CEE amendée par 91/263/EWG, 92/31/CEE

Niederspannungsrichtlinie 73/23/EWG ergänzt durch 93/68/EWG
Low-Voltage Equipment Directive 73/23/EEC amended by 93/68/EEC
Directive des équipements basse tension 73/23/CEE amendée par 93/68/CEE

Angewendete harmonisierte Normen / Harmonized standards applied / Normes harmonisées utilisées

Sicherheit / Safety / Sécurité

EN 61010-1: 1993 / IEC (CEI) 1010-1: 1990 A 1: 1992 / VDE 0411: 1994
Überspannungskategorie / Overvoltage category / Catégorie de surtension: II
Verschmutzungsgrad / Degree of pollution / Degré de pollution: 2

Elektromagnetische Verträglichkeit / Electromagnetic compatibility / Compatibilité électromagnétique

EN 50082-2: 1995 / VDE 0839 T82-2
ENV 50140: 1993 / IEC (CEI) 1004-4-3: 1995 / VDE 0847 T3
ENV 50141: 1993 / IEC (CEI) 1000-4-6 / VDE 0843 / 6
EN 61000-4-2: 1995 / IEC (CEI) 1000-4-2: 1995 / VDE 0847 T4-2: Prüfschärfe / Level / Niveau = 2

EN 61000-4-4: 1995 / IEC (CEI) 1000-4-4: 1995 / VDE 0847 T4-4: Prüfschärfe / Level / Niveau = 3

EN 50081-1: 1992 / EN 55011: 1991 / CISPR11: 1991 / VDE0875 T11: 1992

Gruppe / group / groupe = 1, Klasse / Class / Classe = B

Datum /Date /Date
30.05.1995

Unterschrift / Signature / Signatur

E. Baumgartner
Technical Manager
Directeur Technique

Specifications

(Ref. temp.: 23°C ± 1°C)

Input:

Input voltage range: 10mV...10V
Input impedance: 100kΩ

Signal output:

Output frequencies: 3000 / 3150 Hz
(automatic change)
Short term stability: 5×10^{-5}
Long term stability: 5×10^{-4}
Output voltage: approx. 1V_{rms}
Output impedance: 1.5kΩ
Distortion: <5%

Measuring functions:

Drift

Capturing range: 2400...3780Hz
Measuring range: 19.99%, resolution 0,01%

W&F

Measuring range: 1.999%, resolution 0,01%
Accuracy (static):
6% of value + 4 digit

Weighting filters:

DIN/JIS (DIN 45700)
LIN 0.1...300Hz

Drift: <1,0Hz

Measuring modes:

2-Sigma mode is used for display of measuring values according to DIN, JIS, or LIN

Measuring time (W&F): approx. 5s

DC-output:

Output voltage (W&F): 1V/0.1%
Output voltage (DRIFT): 1V/1%
Output impedance: 300Ω

AC-output 1: (rear side)

Output voltage: 0.1V_{pp}
equivalent to 0.1% drift
Impedance: 1kΩ
The signal is unweighted.

AC-output 2: (rear side)

Output voltage: 0.1V_{pp}
equivalent to 0.1% drift
Impedance: 1kΩ
The signal is weighted according to the selected function

General information:

Supply voltages (from HM8001):
+6V / 230mA
-9V / 110mA
(Σ = 2.37W)

Operating conditions: +10°C bis +40°C
max. relative humidity: 80%

Dimensions (without 22-pin flat connector):

W 135, H 68, D 228 mm

Weight: approx. 650g

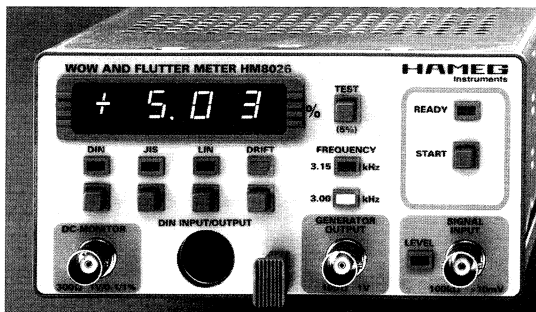

Wow & Flutter Meter HM 8026

- 2 measuring frequencies: 3150Hz and 3000Hz
- Resolution 0.001% (W&F), 0.01% (Drift) resp.
- Digital display
- 2-Sigma mode for W & F
- Monitor output for FFT-analyzer and plotter
- Reference signal for recordings

The W&F Meter HM8026 was developed for measuring speed drift, wow and flutter in analog magnetic recorders, and phonograph turntables. Measurements can be performed in compliance with either DIN/IEC or JIS. Even the latest releases of proposals for the DIN-standards have been taken into account. The vast measurement range permits measurements according to either standard with 3000Hz or 3150Hz test tapes.

Operation of the W&F Meter has been kept consistently simple and user-friendly to facilitate effective and error-free work. Required combinations of standards and test frequency are automatically selected, which eliminates the need for separate calibration. Wow and Flutter measurements are done automatically as soon as the start button is pressed. The measured value is stored and displayed. A self-test function lets you check the accuracy of the instrument.

A crystal-controlled reference signal allows you to make your own recordings that meet the requirements of DIN 45500. In addition, the HM8026 is equipped with two AC monitor outputs for connecting an FFT analyzer or a storage oscilloscope.

Accessories supplied:

**Adapter-Cable for connection to instruments
with RCA-Cinch sockets**

General information

The operator should not neglect to carefully read the following instructions and those of the mainframe HM8001, to avoid any operating errors and to be fully acquainted with the module when later in use.

After unpacking the module, check for any mechanical damage or loose parts inside. Should there be any transportation damage, inform the supplier immediately and do not put the module into operation.

This plug-in module is primarily intended for use in conjunction with the Mainframe HM8001. When incorporating it into other systems, the module should only be operated with the specified supply voltages.

Safety

Every module is manufactured and tested for use only with the mainframe HM8001 according to IEC 348 Part 1 and 1a (Safety requirements for electronic test and measurement equipment). All case and chassis parts are connected to the safety earth conductor. Corresponding to Safety Class 1 regulations (three-conductor AC power cable). Without an isolating transformer, the instruments power cable must be plugged into an approved three-contact electrical outlet, which meets International Electrotechnical Commission (IEC) safety standards.

Warning!

Any interruption of the protective conductor inside or outside the instrument or disconnection of the protective earth terminal is likely to make the instrument dangerous. Intentional interruption is prohibited.

The instrument must be disconnected and secured against unintentional operation if there is any suggestion that safe operation is not possible. This may occur:

- if the instrument has visible damage,
- if the instrument has loose parts.
- if the instrument does not function,
- after long storage under unfavourable circumstances (e.g. outdoors or in moist environments),
- after excessive transportation stress (e.g. in poor packaging).

When removing or replacing the metal case, the instrument must be completely disconnected from the mains supply. If any measurement or calibration procedures are unavoidable on the opened-up instrument, these must only be carried out by qualified personnel acquainted with the danger involved.

Symbols as Marked on Equipment



DANGER High voltage



Protective ground (earth) terminal.



ATTENTION refer to manual.

Operating conditions

The ambient temperature range during operation should be between +10°C and +40°C and should not exceed -40°C or +70°C during transport or storage. The operational position is optional, however, the ventilation holes on the HM8001 and on the plug-in modules must not be obstructed.

Warranty

Before being shipped, each plug-in module must pass a 24 hour quality control test.

Provided the instrument has not undergone any modifications Hameg warrants that all products of its own manufacture conform to Hameg specifications and are free from defects in material and workmanship when used under normal operating conditions and with the service conditions for which they were furnished.

The obligation of HAMEG hereunder shall expire two (2) years after delivery and is limited to repairing, or at its option, replacing without charge, any such product which in Hameg's sole opinion proves to be defective with the scope of this warranty.

This is Hameg's sole warranty with respect to the products delivered hereunder. No statement, representation, agreement or understanding, oral or written, made by an agent, distributor, representative or employee of, which is not contained in this warranty will be binding upon Hameg, unless made in writing and executed by an authorized Hameg employee. Hameg makes no other warranty of any kind whatsoever, expressed or implied, and all implied warranties of merchantability and fitness for a particular use which exceed the aforementioned obligation are hereby disclaimed by Hameg to be liable to buyer, in contract or in tort, for any special, indirect, incidental or consequential damages, expenses, losses or delays however caused.

In case of any complaint, attach a tag to the instrument with a description of the fault observed. Please supply name and department, address and telephone number to ensure rapid service.

The instrument should be returned in its original packaging for maximum protection. We regret that transportation damage due to poor packaging is not covered by this warranty.

Maintenance

The most important characteristics of the instruments should be periodically checked according to the instructions provided in the sections "Operational check" and "Alignment procedure". To obtain the normal operating temperature, the mainframe with inserted module should be turned on at least 60 minutes before starting the test. The specified alignment procedure should be strictly observed.

When removing the case detach mains/line cord and any other connected cables from case of the mainframe HM8001. Remove both screws on rear panel and, holding case firmly in place, pull chassis forward out of case. When later replacing the case, care should be taken to ensure that it properly fits under the edges of the front and rear frames. After removal of the two screws at the rear of the module, both chassis covers can be lifted. When reclosing the module, care should be taken that the guides engage correctly with the front chassis.

Operation of the module

Provided that all hints given in the operating instructions of the HM8001 Mainframe were followed especially for the selection of the correct mains voltage start of operation consists practically of inserting the module into the right or left opening of the mainframe. The following precautions should be observed:

Before exchanging the module, the mainframe must be switched off. A small circle (o) is now revealed on the red power button in the front centre of the mainframe.

If the BNC sockets at the rear panel of the HM8001 unit were in use before, the BNC cables should be disconnected from the basic unit for safety reasons. Slide in the new module until the end position is reached.

Before being locked in place, the cabinet of the instrument is not connected to the protective earth terminal (banana plug above the mainframe multipoint connector). In this case, no test signal must be applied to the input terminals of the module.

Generally, the HM8001 set must be turned on and in full operating condition, before applying any test signal. If a failure of the measuring equipment is detected, no further measurements should be performed. Before switching off the unit or exchanging a module, the instrument must be disconnected from the test circuit.

Controls and indicators of the HM 8026

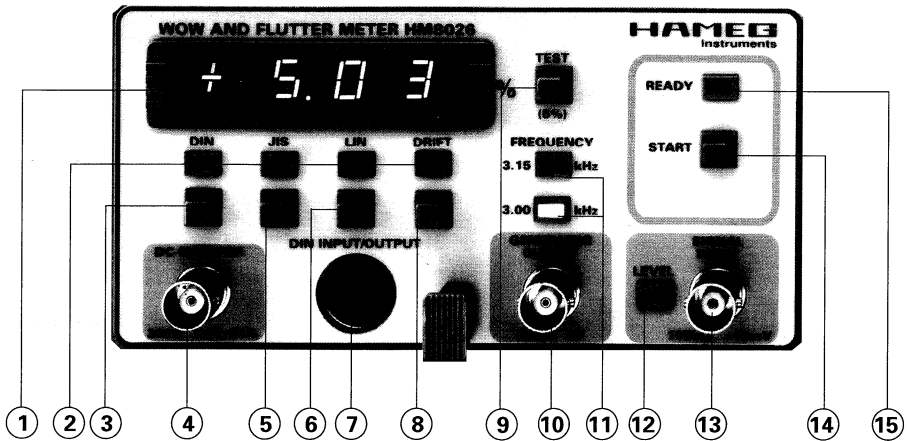

① Display (7-segment LED digits)

3½-digit digital display of measured drift or wow and flutter values. The values are displayed with appropriate decimal point and sign, depending on the selected operating mode.

② Function indicators

The LEDs indicate the selected measurement mode.

③ DIN (pushbutton)

For selecting DIN/IEC mode. When pressed, the 3150-Hz reference oscillator is activated.

④ DC MONITOR (BNC jack)

Output jack for connecting a recording instrument. The output voltage is proportional to the measured error percentage (0.1 V/% for drift, and 1 V/% for W&F).

⑤ JIS (pushbutton)

For selecting JIS mode. When pressed, the 3000-Hz reference oscillator is activated.

⑥ LIN (pushbutton)

For selecting LIN mode. The reference oscillator is not changed.

⑦ DIN INPUT/OUTPUT (5-pin DIN jack)

Input and output for connecting a magnetic recording device using a DIN cable.

⑧ DRIFT (pushbutton)

For selecting drift (speed) measurement. The reference oscillator is not changed.

⑨ TEST (pushbutton)

In DRIFT mode, a test can be performed to check the accuracy of the HM 8026. Hold this button depressed for at least 5 seconds; the value $+5.00 \pm 0.06$ (%) should be displayed.

⑩ GENERATOR OUTPUT (BNC jack)

Output of the sinusoidal reference signal with approx. $1 V_{rms}$; $R_i = 1.5 k\Omega$.

⑪ FREQUENCY (LEDs)

These LEDs indicate which reference oscillator is active.

⑫ LEVEL (LED)

This LED illuminates when an input signal of $10 mV_{rms}$ or greater is applied. When this is the case, no signal can be taken off jacks ⑦ and ⑩.

⑬ SIGNAL INPUT (BNC jack)

Signal input. The permissible input voltage range is 0.01 to $10 V_{rms}$. This input is protected against overvoltages up to $50 V_{rms}$.

⑭ START (pushbutton)

Pressing this button initiates a wow and flutter measurement.

⑮ READY (LED)

This LED lights up to indicate that the instrument is ready for operation.

General

No special knowledge is required to operate the HM 8026. The front panel is clearly organized and non-essential functions have left out, thus permitting you to begin work efficiently immediately after switching on the unit.

For best results when using the HM 8026, please observe the instructions and information given in this manual. The section "General information about drift and wow-and-flutter measurements" below contains basic pointers on how to use "wow-and-flutter"-meters.

General information about drift and wow-and-flutter measurements

The acoustic properties of sound recording and reproduction devices are described in standards. DIN 45500 and DIN 54511 are examples of such standards for phonograph turntables, tape recorders, cassette recorders and players, and hifi equipment. IEC 386 and DIN 45507 are specifically devoted to the measurement of speed fluctuations. In addition, the Japanese standard (JIS) is occasionally applied for performing measurements. All of these standards (including the most recent draft for a revised version of DIN/IEC 386 have been taken into account when designing the HM 8026.

A fundamental distinction is made long-term and short-term speed fluctuations. "Drift" is defined as the deviation of actual speed from rated speed, determined as an average over 30 seconds. "Wow" and "flutter", by contrast, are terms used to describe short-term fluctuations from an average speed. "Flutter" refers to such fluctuations that occur at a low audio or an infrasonic rate (0.5 to 200 Hz), especially in the higher portion of this range, while "wow" is restricted to the audible effect of a low-frequency flutter occurring at a rate of 0.5 to 10 Hz.

The human ear responds with varying sensitivity to carrier and modulation frequencies. Both frequencies have been standardized: the carrier frequency used for measurements is 3.15 kHz (DIN/IEC) or 3.00 kHz (JIS), and the curve used for assessing the modulation frequency reflects the sensitivity of the human ear up to a maximum of 4 Hz (for all 3 standards). A device for measuring speed errors must therefore continuously compare two frequencies with one another: the actual measured frequency taken from the test object on the one hand, and the reference frequency on the other, which is generated with great accuracy within the meter itself (and is also output for recording purposes). The difference between the two frequencies is determined using a special technique involving evaluation filters. The HM 8026 uses the 2-sigma method proposed in the standard.

It is not usually very difficult to measure the actual speed, since the changes occur at a very slow rate and no display or reading problems arise. If longer-term changes occur, you have the option of capturing

the values over an extended time period and subsequently evaluating them according to previously stipulated criteria. Such changes can be caused by temperature or mechanical stresses. In most cases, however, it is only of interest to capture the low-frequency changes occurring over a short time (wow and flutter), and it is not necessary to apply complicated techniques for determining the average over an extremely long period of time (speed drift).

Fluctuations in the frequency modulation of sound recordings are always subject to rapid variations. If the measured values are displayed as recommended by DIN 45507, then they jump about and are very difficult to read. Point 4.1 of DIN 45507 specifies that the maximum values at any given time must be read. Isolated peak values caused by random events distort the results, however. Because of this, DIN/IEC 386 lists a second method that is superior to the conventional one: the 2-sigma technique.

During a preset measurement time of at least 5 seconds, the momentary speed deviations are written into memory and compared with a threshold voltage. Only those measured values are displayed that exceed the threshold (in the positive or negative direction) during at least 5% of the total time.

With greatly fluctuating measurement values, which are always obtained with tape and cassette equipment, the results of two successive measurements performed within a short period of time will not be exactly identical, in spite of the 2-sigma method. Therefore it is helpful to average several successive measured values in order to enhance the reliability of the measured results.

The results of measurement are also greatly influenced by the auxiliary materials used, especially by test records, tapes and cassettes. It is important to be aware of this fact. An instrument for measuring speed fluctuations must of course have a high resolution. But the error introduced by the auxiliary test materials is typically greater by an order of magnitude than that of the meter itself, thus coming dangerously close to the size of the actual measured values.

The Japanese standard differs considerably from DIN/IEC. The measurement values obtained cannot be compared, nor can they be converted from one system to the other. Whereas the DIN standard calls for measurement at a carrier frequency of 3150 Hz, JIS stipulates a frequency of 3000 Hz. In contrast to the DIN approach, in which the peak value is captured, JIS measurements determine the "effective" or root mean square value of fluctuations in speed. In most cases, this yields more favorable results.

Digital sound reproduction devices cannot be measured with wow and flutter meters, because the constancy of their speed - both long- and short-term - is determined by internal oscillators that are in the same accuracy class as the generators of the meters.

Performing measurements with the HM 8026

The HM 8026 has been intentionally designed for practical use. It includes all functions needed to evaluate the quality of analog sound recording and reproduction devices. It also has outputs for frequency analyses (Fast Fourier Transform). Because it is equipped with two independent crystal-controlled oscillators, the HM 8026 can be checked and calibrated at any time. Because the DIN and JIS pushbuttons are directly linked to the oscillator frequency, it is not possible to forget to change the frequency when switching standards. Since the default setting is always DIN (3.15 kHz), the instrument is ready to perform measurements using the European standard immediately after being switched on.

The input signal for evaluation is applied to the BNC jack "Signal input" (13). Alternatively, it is possible to use the DIN jack (7) for this. The input voltage is tested to see if its amplitude is large enough. As soon as an input voltage of at least 10 mV is applied, the HM 8026 is enabled for measurement. This state is indicated by the "Level" LED (12). Once the desired test function is selected, the HM 8026 is ready to start measurements.

"READY" LED

This red LED lights up to indicate that the instrument is ready to perform measurements. This happens 2 seconds after a suitable signal is applied. If the input voltage or if the measured frequency is too low (less than 10 mV or 2400 Hz, respectively), then any measurements in progress are interrupted and the display shows zero. If an input signal has applied for a longer time without triggering a wow and flutter measurement, a value greater than zero may also be displayed; it is erased as soon a measurement is triggered.

"START" button

Pressing this pushbutton initiates automatic measurement of wow and flutter. This is only possible if an input signal with a frequency of at least 2400 Hz and an amplitude > 10 mV is applied. While wow and flutter or drift measurements are being performed, pressing this button has no effect. The 2-sigma method ignores random signal spikes if their total duration is less than 5% of the measurement time. At the end of the measurement time of about 6 seconds, the determined measurement value is displayed and remains stored in memory for several seconds. The display is cleared as soon as a new measurement is initiated or the input signal is switched off. To improve accuracy, it is a good idea to repeat all measurements at least 3 times and average them.

Selecting the test function

The HM 8026 places 5 test functions at your disposal:

- Wow and flutter measurement according to DIN with 2-sigma evaluation
- Wow and flutter with linear evaluation
- Wow and flutter according to JIS with rms evaluation
- Drift with a carrier frequency of 3150 Hz
- Drift with a carrier frequency of 3000 Hz

Use the pushbuttons on the front panel (2,5,6,8) to select the desired functions. Your choices are indicated by the corresponding LEDs. The appropriate carrier frequency is automatically selected. It can only be manually selected for drift measurements.

Output for frequency analysis instruments

At the jacks on the rear of the mainframe HM 8001, test signals can be taken off for evaluation by a frequency analyzer. The unaltered test signal appears at jack 1, and jack 2 (in later versions of the HM 8001 only) makes available the measured signal, in either processed or unprocessed form depending on the selected operating mode. The sensitivity of jack 1 is 1 V/% for W&F measurements and 0.1 V/% for drift measurements. It is also possible to simultaneously measure the drift using the HM 8026's display while performing frequency analysis of wow and flutter on a connected external device.

The DC output is not affected by the 2-sigma process. The speed fluctuations are output with correct polarity in frequency-attenuated form. In the case of W&F measurements, the absolute-value signal is transformed into the corresponding envelope curve, applying a response time constant of about 20 ms and two hold time constants.

Generator output and DIN input/output

The DIN jack (7) is an input/output for connection of a magnetic sound recording/playing device using a DIN interconnect cable. Both recordings and sound reproduction are possible. The reference signal is available as a sine-wave signal at a level of approx. 1 V_{rms} and an internal resistance of 1 M Ω . At jack (10), a sinusoidal reference signal appears with the frequency of the momentarily active oscillator, a level of about 1 V_{rms}, and an internal resistance of approx. 1.5 K Ω . Output signals generated by the HM 8026 are only available when no signal is being applied to the input for evaluation.

TEST

In DRIFT mode, a self-test can be performed to check the accuracy of the HM 8026. If the button (9) "Test" is held depressed for at least 5 seconds, the value +5.00 \pm 0.06 (%) should be displayed.

Calibration instructions

Switch the instrument on about 30 minutes before calibrating so it can warm up. Because the amplifier is sensitive to hum, do the calibration on a shielded workbench only. Calibrations should only be done by persons who are familiar with the technical attributes of the HM 8026. Knowledge and observance of the pertinent safety regulations are required.

Required equipment: mainframe HM 8001, plug adapter HZ 89, HM 205-3, HM 8011-3, two HM 8030-4

1. Visual inspection

After power-up the display must show .XXX. The first digit and the sign must not illuminate. The value of the last three digits is still undefined.

The default mode (DIN) must be indicated by the red LED. The green LED for 3150 Hz must also be lit. All other LEDs must be dark.

1.1 Checking the mode selection switches

One after the other, press the JIS, LIN and DRIFT buttons. In each case, the LED above the button should light up while the others extinguish. When the JIS button is pressed, the LED indicator for 3150 Hz must also simultaneously extinguish and the orange LED for 3000 Hz must light up in its place. Afterwards, press the DIN button again.

2. Zero calibration

2.1 Base settings: set all potentiometers to their center positions.

2.2 Adjust P002 so that 0 ± 0.5 mV DC is measured at test point MP2.

2.3 Adjust P001 so that 0 ± 0.5 mV DC is measured at test point MP1. The display should show .000. If necessary, carefully fine adjust P001.

2.4 Adjust P004 so that -10.0 mV DC is measured at test point MP4 (compensation for noise voltage).

2.5 Adjust P007 so that 0 ± 0.3 mV DC is measured at test point MP6.

3. Testing and calibration with audio-frequency signal

3.1 Check the signal at the GENERATOR OUTPUT jack. The scope should display a sinewave signal without visible distortions with a level of approx. $3 V_{pp}$ ($\leq 5\%$). The frequency must change when the JIS and DIN buttons are pressed (3150 Hz - 3000 Hz - 3150 Hz).

3.2 Now check the signal at the DIN jack (pin 1 on the left). It must be identical with the signal at GENERATOR OUTPUT. Keep in mind that a voltage drop can be caused by the termination resistance you are using ($R_{int} = 1 M\Omega$).

3.3 Apply a signal with a frequency of exactly 3150 Hz and an amplitude of $12 mV_{pp}$ to the SIGNAL INPUT jack. This should cause the following to happen:
The output signals at the GENERATOR OUTPUT and DIN outputs must disappear (it is enough to check this at only one of them).
The green LEVEL LED must light up.

About 2 seconds after applying the input voltage, the red READY LED must light up.

The same effects must be caused when the signal is applied to the DIN jack (pin 3 on the right).

3.4 Adjust P006 so that a voltage of 0 ± 0.3 mV DC is measured at test point MP6. Then switch off the signal and repeat the zero calibration as described in 2.5.

Afterwards apply the test signal again, and readjust P006 for a zero-volt output at test point MP6. Then press the DRIFT button and check the display reading. It must show ± 0.00 . If necessary, carefully fine adjust P007.

3.5 Now press the TEST button and hold it depressed. Measure the DC voltage level at test point MP6; it should be 500 ± 1 mV. It can be precisely calibrated with P005.

3.6 Press the TEST button again and hold it depressed, like before. After a few seconds the display should read $+5.00$. P008 can be used to calibrate this value. A voltage of 500 ± 20 mV should be measured at the DC-MONITOR jack.

3.7 Press the DIN button once again, and check the display. It should read .000 again.

4. Dynamic control of the 2-sigma configuration

4.1 Apply an unmodulated signal with a frequency of approx. 3150 Hz to the SIGNAL INPUT jack. Apply a square-wave signal with a frequency of 50 Hz and an amplitude of $100.0 mV_p$ to test point MP5 (only the positive half-wave counts; the amplitude of the negative half-wave is not critical). The output impedance of the generator must not exceed 100Ω .

Press the START button and observe what happens at test point MP2. The voltage at MP2 should climb to a level of 300 ± 15 mV DC during the 5-second measurement time. The display reading should also be within the same tolerance range.

Now switch the generator to a triangular waveform (back-to-back sawtooth). Check to make sure that the amplitude reading continues to be exactly $100 mV$.

Repeat the test procedure. After elapse of the measurement time, the voltage at test point MP2 should have climbed to 270 ± 20 mV DC. The display reading should also be within the same tolerance range (that voltage is displayed at which unconsidered voltage spikes occurred during 5% of the total time).

5. Checking and calibration with a frequency-modulated signal

Note: Before performing measurements and calibration, terminate FFT1 and FFT2 with a $0.47-\mu F$ capacitor.

5.1 Press the LIN button. Apply a signal with a carrier frequency of approx. 3150 Hz that is modulated with a sinewave signal at a frequency of 4 Hz and a modulation factor of $\pm 1.5\%$ ($1500 mV_p$ at FFT OUT2; only the positive half-wave is considered).

Measure the signal at FFT OUT2 at the cutoff frequencies: the signal should drop back by no more than $100 mV$ when you vary the modulation frequency to 0.4 Hz or 40 Hz without changing the modulation factor.

Reset the modulation frequency to 4 Hz. Now press the DIN button. The output signal must not change by more than $\pm 100 mV$ ($= 0.6$ dB).

Set the level to exactly $1500 mV$ by fine adjusting the modulation factor.

Now measure the signal at FFT OUT2 again at the cutoff frequencies: 0.4 Hz a level of $250 \pm 50 mV$ should be measured, and $450 \pm 50 mV$ at 40 Hz.

5.2 Switch to output FFT1, and repeat the last measurement (DIN).

The signal must not fall by more than $100 mV$ when you change the modulation frequency to 0.4 Hz or 40 Hz without varying the modulation factor.

5.3 Change back to a modulation frequency of 4 Hz and an output level at FFT1 of $1500 mV_p$.

Using the scope, watch what happens at test point MP4. You will see the demodulated and rectified voltage. Adjust P003 so that the half-waves show roughly equally great peak amplitudes. The peak amplitude value should be $1500 mV \pm 100 mV$.

6. Concluding the tests

6.1 Switch off all signal voltages.

Briefly check the display reading once again in DIN mode, and if necessary readjust P001 to obtain .000. Check the display reading in DRIFT mode, and if necessary readjust P007 to obtain ± 0.00 .

Bestückungsplan, Digitalanzeige
Component Locations, Digital Display

Implantation des composants, Affichage numérique
Localizacion de componentes, Indicador digital

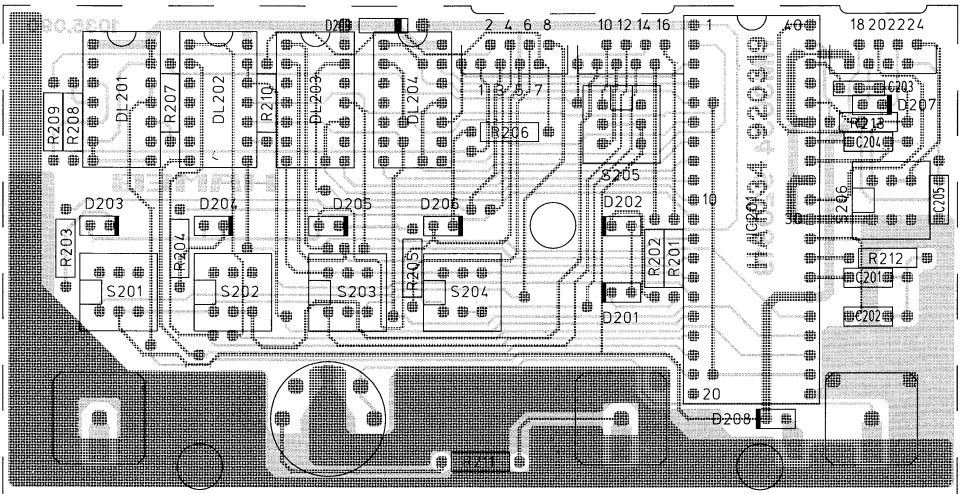

Bestückungsplan, Grundplatte
Component Locations, Main Board

Implantation des composants, Circuit principal
Localizacion de componentes, Placa base

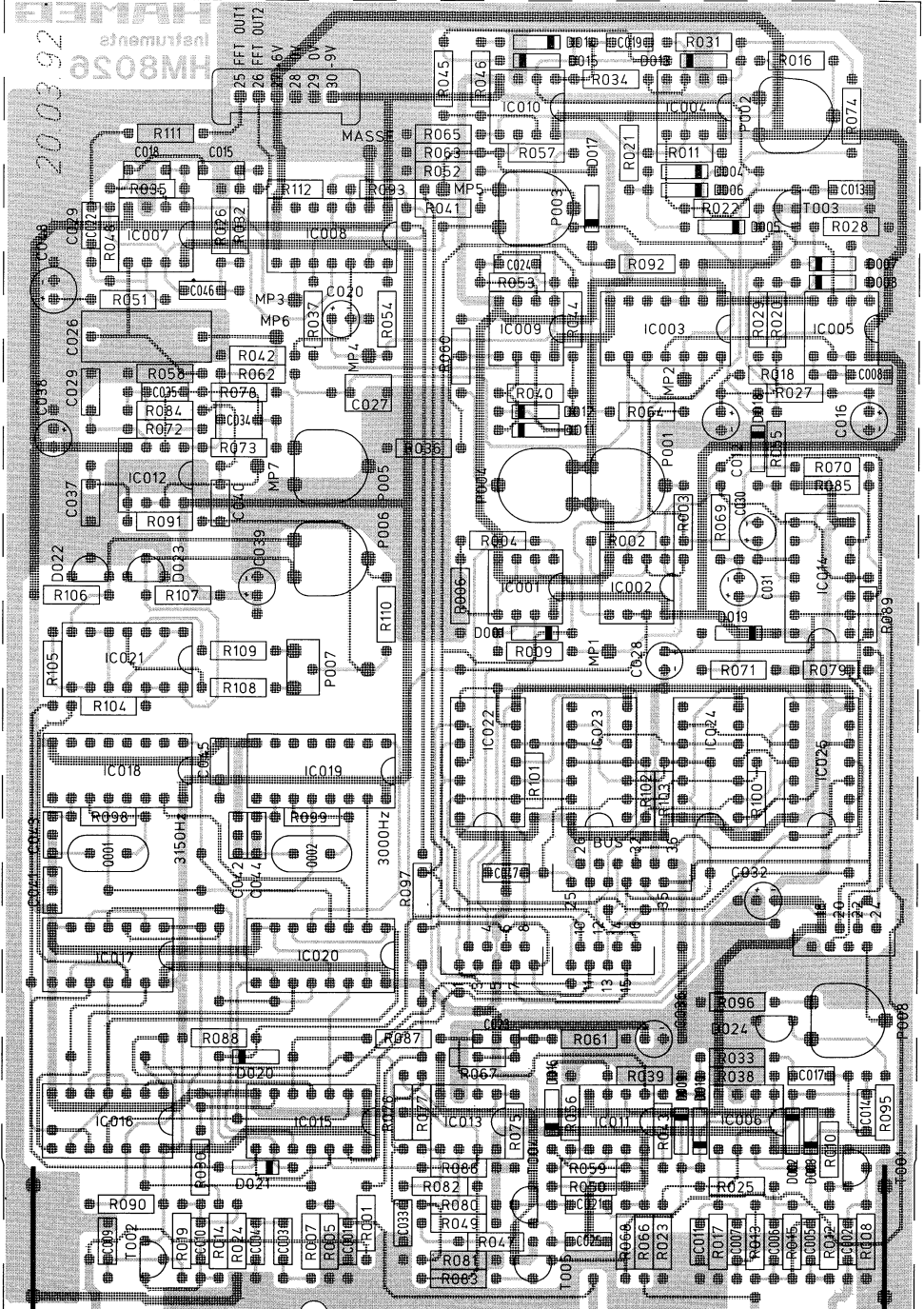

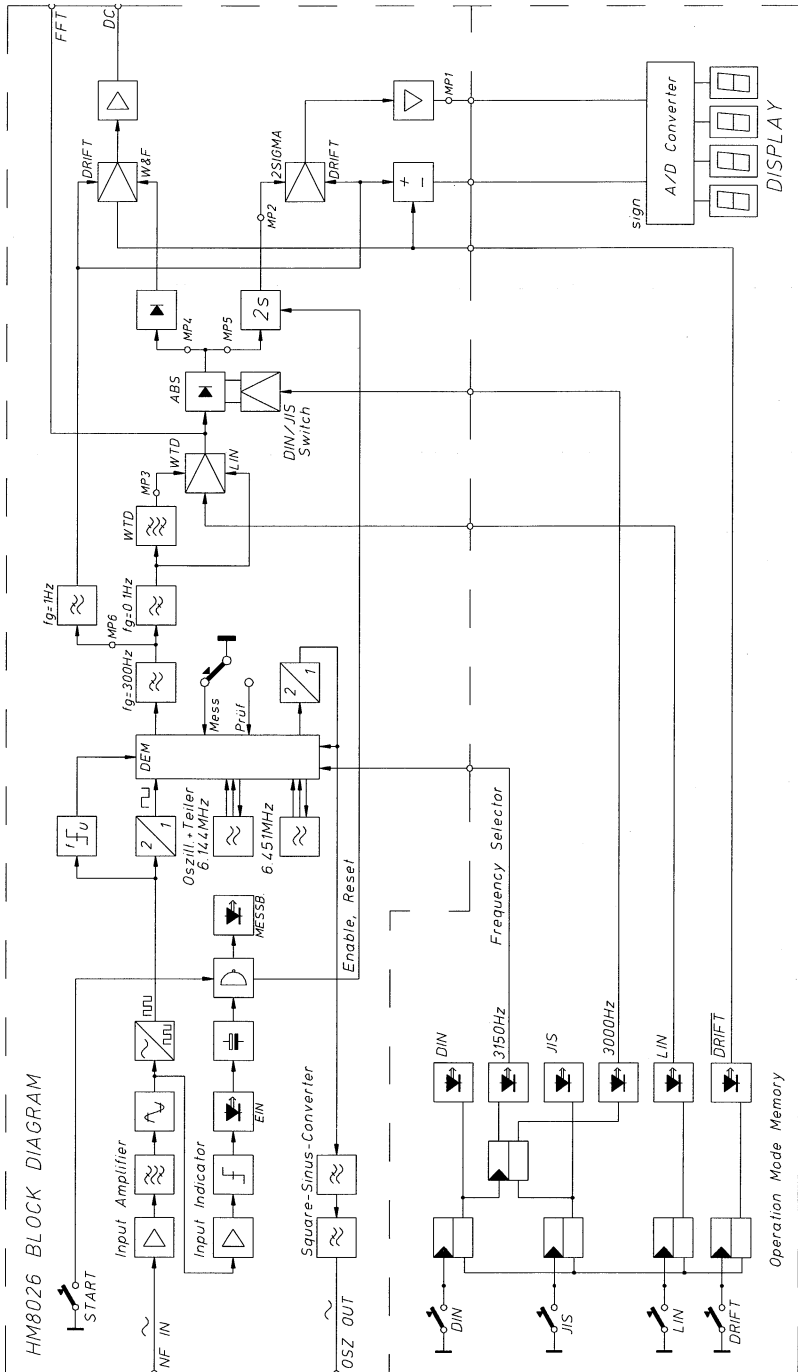

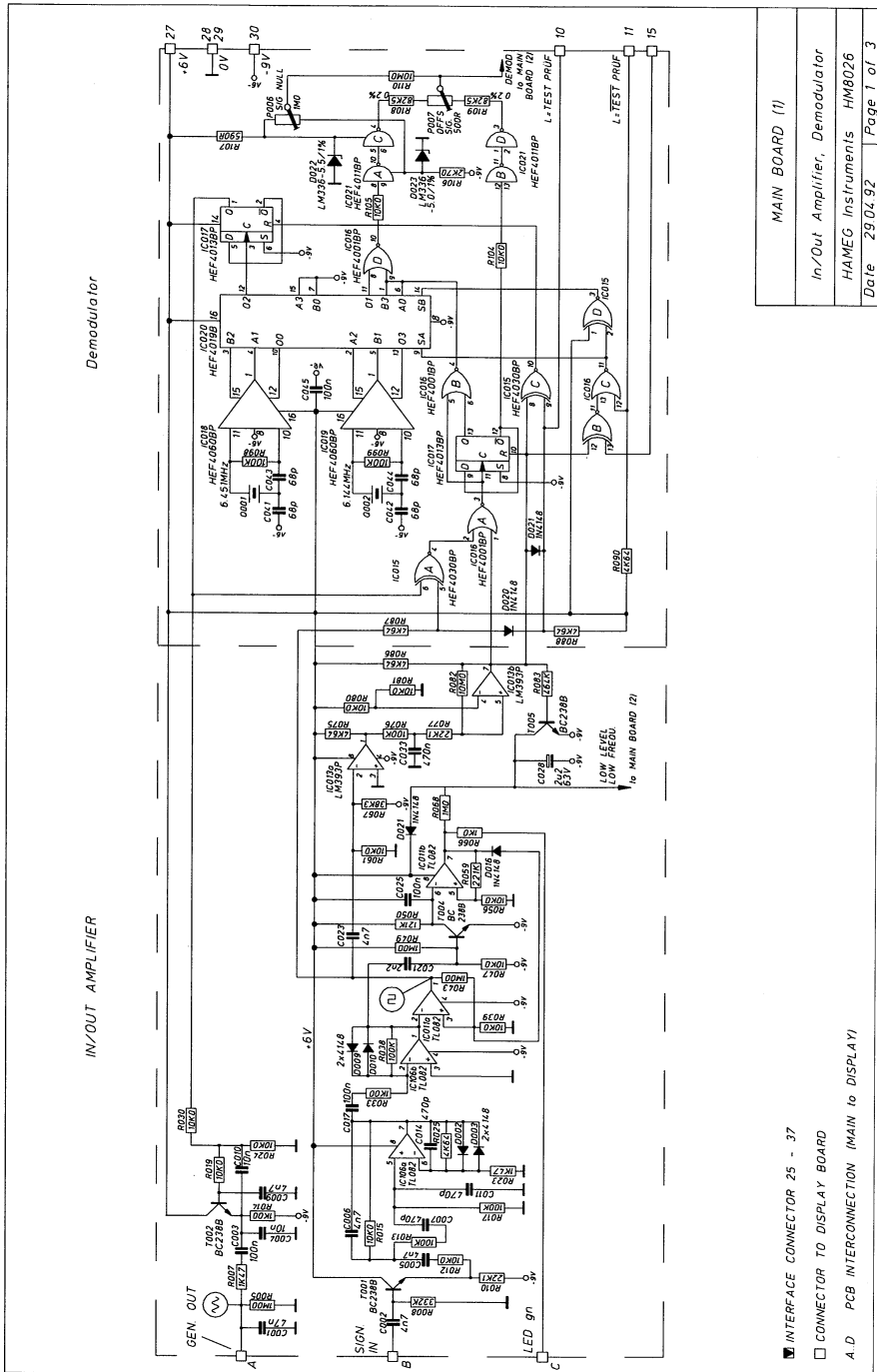

MAIN BOARD (1)
In/Out Amplifier, Demodulator
HAMEG Instruments HM8026
Date 29.04.92 Page 1 of 3

■ INTERFACE CONNECTOR 25 - 37

□ CONNECTOR TO DISPLAY BOARD

A.D PCB INTERCONNECTION (MAIN to DISPLAY)

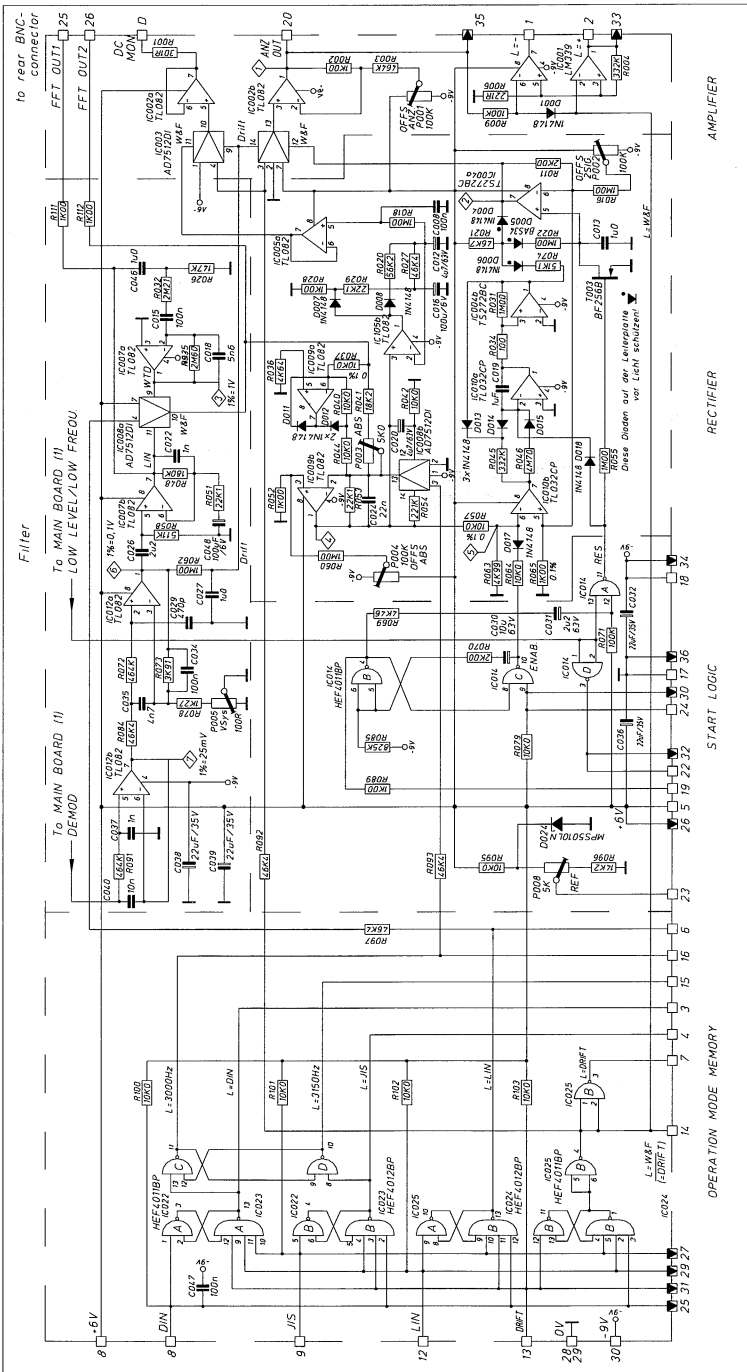

MAIN BOARD (2)
Logic Control, Filter
HAMEG Instruments HM8026
Date: 29.01.92 Page 2 of 3

- ▼ INTERFACE CONNECTOR 25 - 37
- CONNECTOR TO DISPLAY BOARD
- A D PCB INTERCONNECTION (MAIN to DISPLAY)

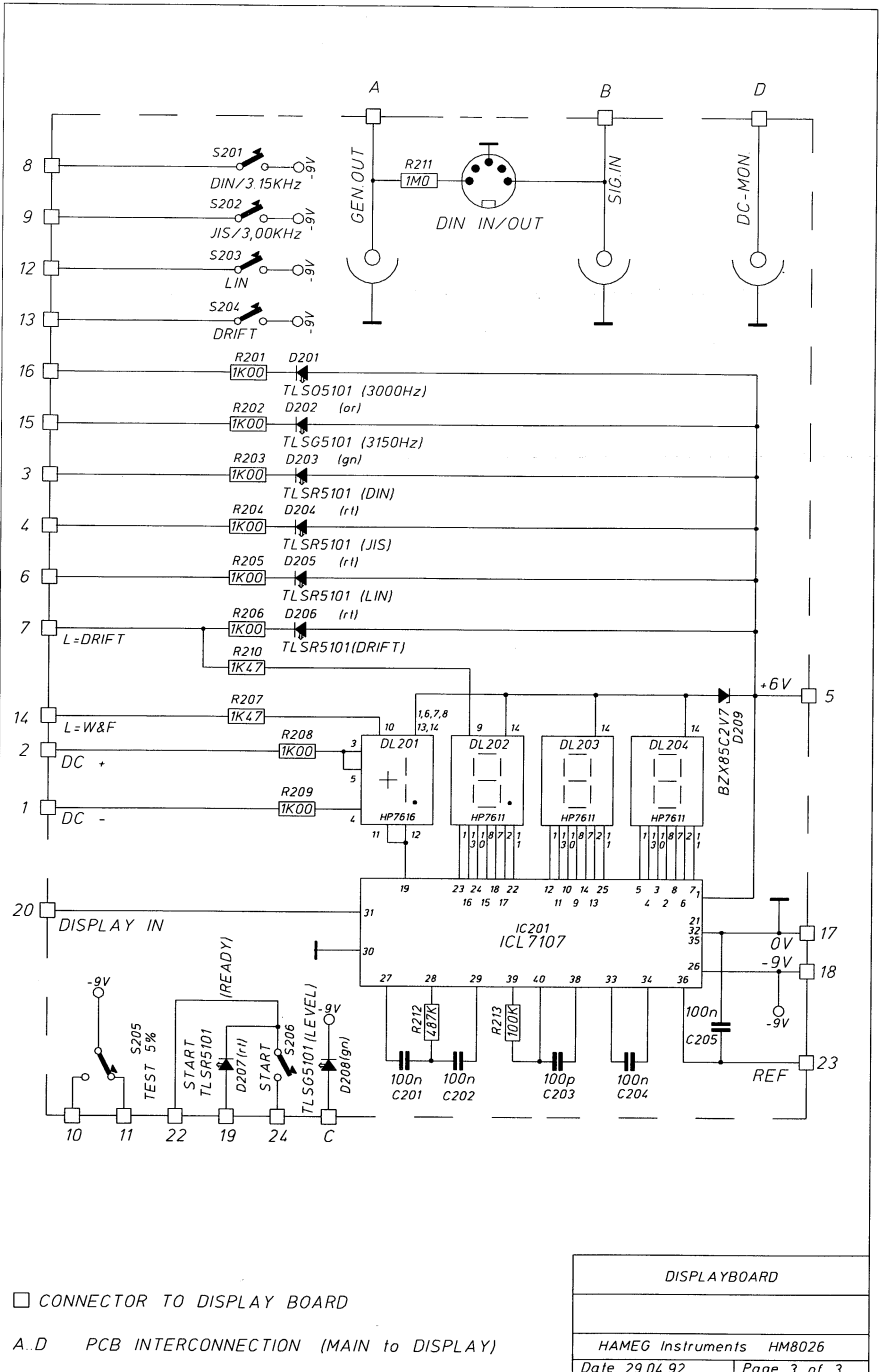

HAMEG[®]

Instruments

Oscilloscopes

Multimeters

Counters

Frequency Synthesizers

Generators

R- and LC-Meters

Spectrum Analyzers

Power Supplies

Curve Tracers

Time Standards

Germany

HAMEG Service

Kelsterbacher Str. 15-19
60528 FRANKFURT am Main
Tel. (069) 67805 - 24 -15
Telefax (069) 67805 - 31
E-mail: service@hameg.de

HAMEG GmbH

Industriestraße 6
63533 Mainhausen
Tel. (06182) 8909 - 0
Telefax (06182) 8909 - 30
E-mail: sales@hameg.de

France

HAMEG S.a.r.l

5-9, av. de la République
94800-VILLEJUIF
Tél. (1) 4677 8151
Telefax (1) 4726 3544
E-mail: hamegcom@magic.fr

Spain

HAMEG S.L.

Villarroel 172-174
08036 BARCELONA
Teléf. (93) 4301597
Telefax (93) 321220
E-mail: email@hameg.es

Great Britain

HAMEG LTD

74-78 Collingdon Street
LUTON Bedfordshire LU1 1RX
Phone (01582) 413174
Telefax (01582) 456416
E-mail: sales@hameg.co.uk

United States of America

HAMEG, Inc.

266 East Meadow Avenue
EAST MEADOW, NY 11554
Phone (516) 794 4080
Toll-free (800) 247 1241
Telefax (516) 794 1855
E-mail: hamegny@aol.com

Hongkong

HAMEG LTD

Flat B, 7/F,
Wing Hing Ind. Bldg.,
499 Castle Peak Road,
Lai Chi Kok, Kowloon
Phone (852) 2 793 0218
Telefax (852) 2 763 5236
E-mail: hameghk@netvigat.com

44 - 8026 - 0010